



CUSTOM MOUNTING SOLUTIONS FOR MARINE ELECTRONICS



LINE DRAWING

3D RENDERING

FINISHED PRODUCT

Complete Custom Design & Production Specific To Your Application

- Experienced Design / Engineering Team
- Modeled Specific To Your Personal Design & Needs
- Industries Fastest Turn-around Time
- Unsurpassed Quality & Customer Service

Design → *Model* → *Production* → *Delivery Timeline*

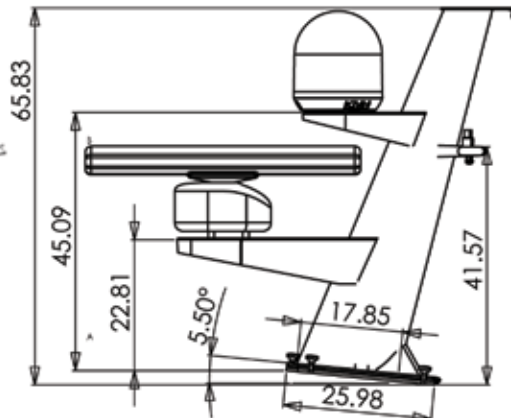
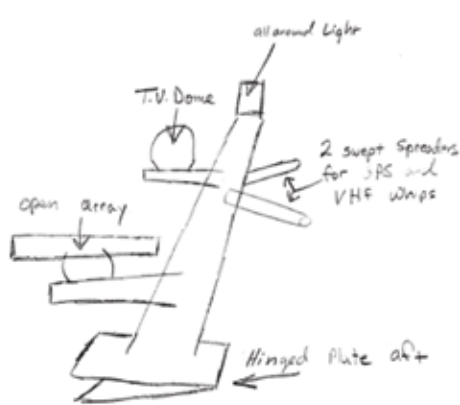

DAY 1

Napkin Sketch From Customer
(rough dimensions, electronics, accessories, etc)

DAY 2

Seaview Provides Dimensional
CAD Drawing For Customer Review

DAY 3

Seaview Presents 3D Model
Following CAD Approval

Custom Mount Design and Manufacturing Service

- Prices dependant on complexity
- Short turn around time of 3 - 4 weeks
- Low cost delivery options

Please visit us online at www.seaviewglobal.com to view our custom examples. For pricing please call us at (800) 523-7558.



Photo Courtesy of American Tug: Shown on American Tug 49

3 - 4 WEEKS

Seaview Completes Production & Mast Is Shipped Ready For Installation

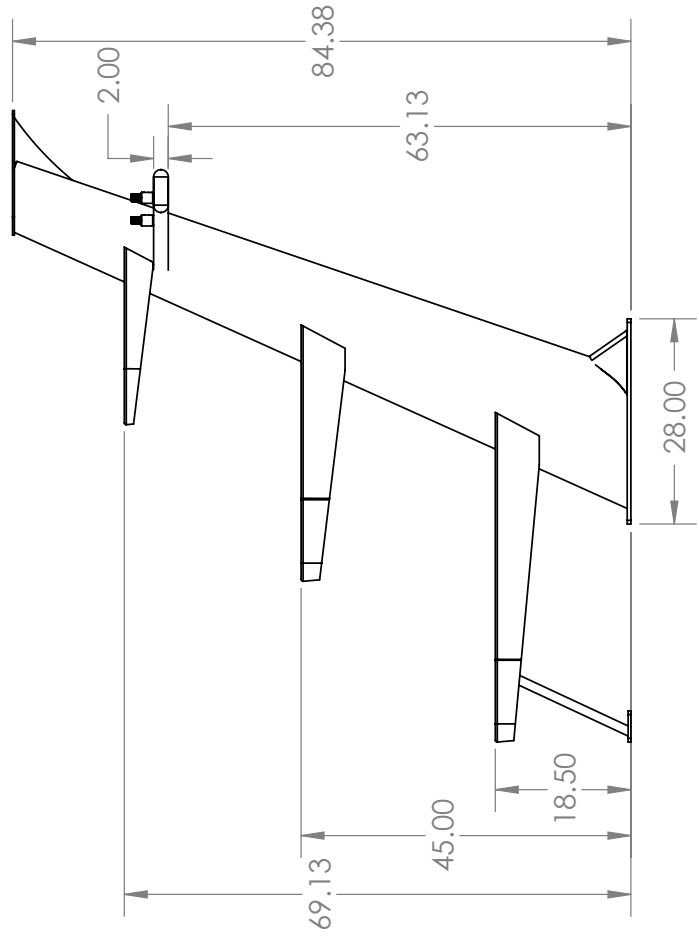
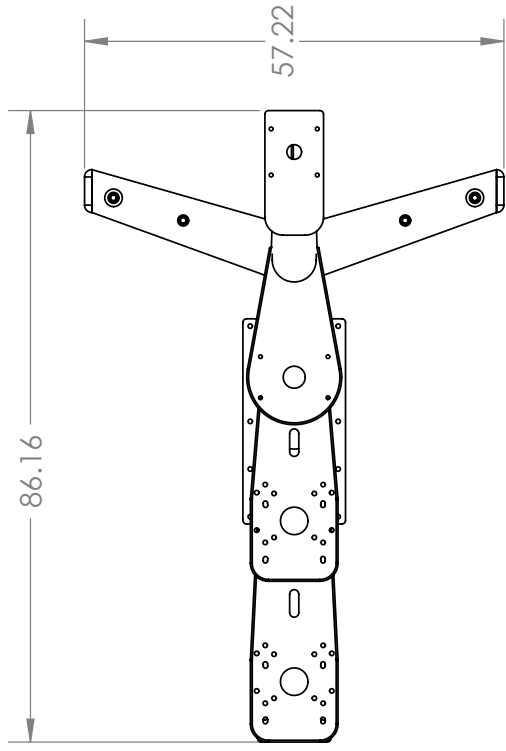

PROPRIETARY AND CONFIDENTIAL

THE INFORMATION CONTAINED IN THIS DRAWING IS THE SOLE PROPERTY OF PYI Inc. ANY REPRODUCTION IN PART OR AS A WHOLE WITHOUT THE WRITTEN PERMISSION OF PYI Inc IS PROHIBITED.

PYI Inc

TITLE:

Model 1

REV: 092110

LIST PRICE GUIDE:

Please call

SCALE: NOT TO SCALE

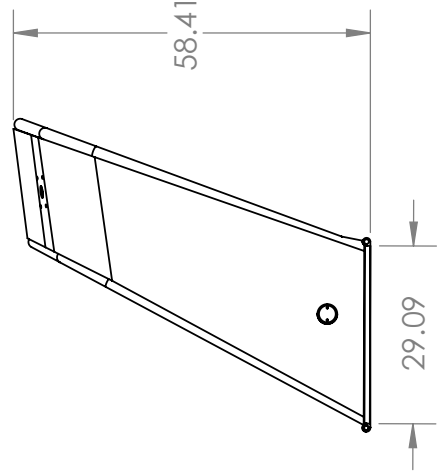
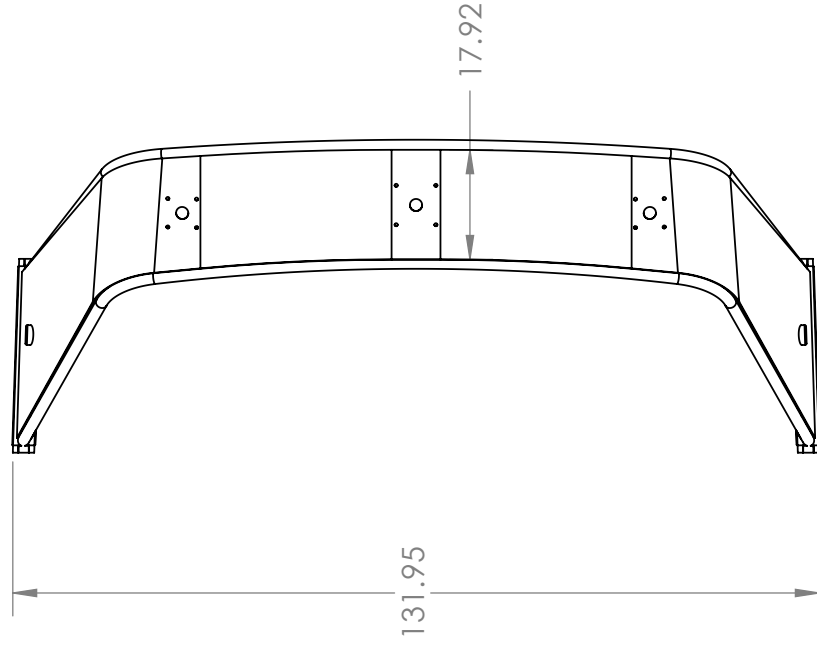

PROPRIETARY AND CONFIDENTIAL

THE INFORMATION CONTAINED IN THIS DRAWING IS THE SOLE PROPERTY OF PYI Inc. ANY REPRODUCTION IN PART OR AS A WHOLE WITHOUT THE WRITTEN PERMISSION OF PYI Inc IS PROHIBITED.

PYI Inc

TITLE: **Model 35**

REV: 092110

LIST PRICE GUIDE: **Please call**

SCALE: **NOT TO SCALE**

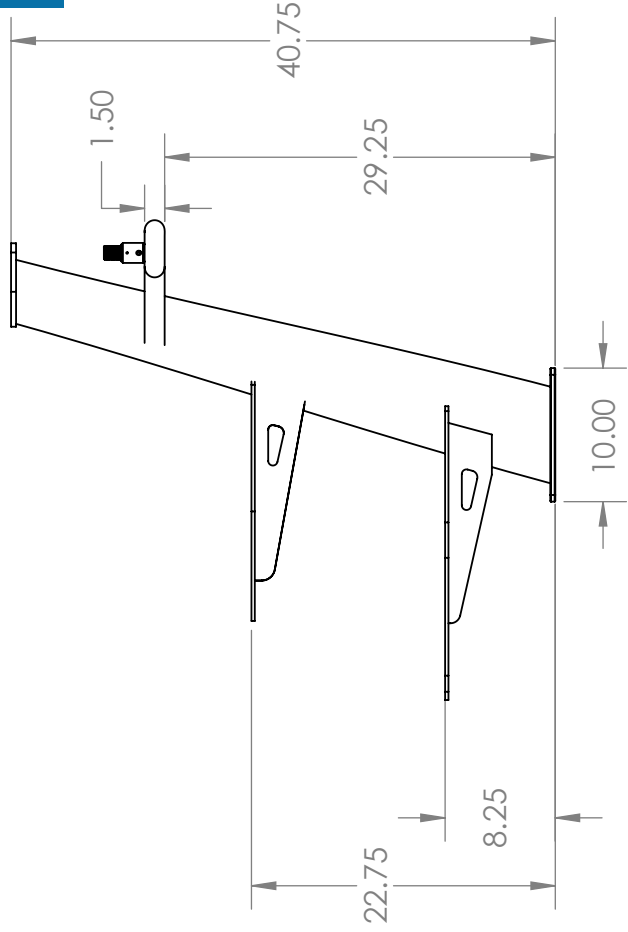
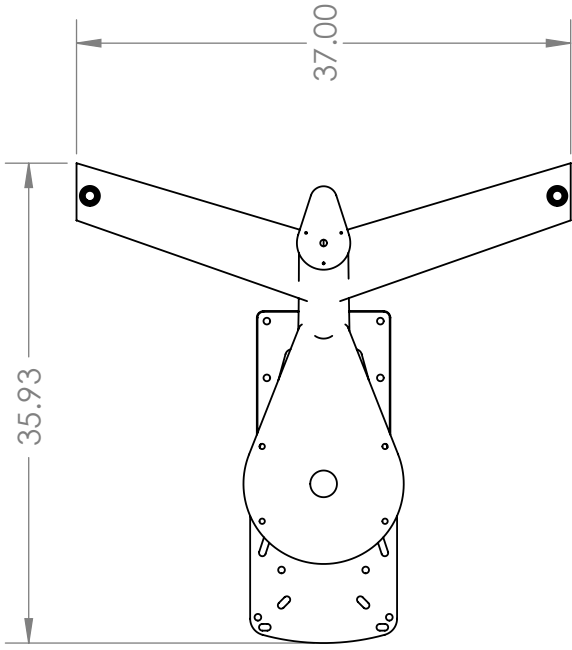

PROPRIETARY AND CONFIDENTIAL

THE INFORMATION CONTAINED IN THIS DRAWING IS THE SOLE PROPERTY OF PYI Inc. ANY REPRODUCTION IN PART OR AS A WHOLE WITHOUT THE WRITTEN PERMISSION OF PYI Inc IS PROHIBITED.

PYI Inc

TITLE: **Model 14** REV: 092110

LIST PRICE GUIDE:
Please call

SCALE: NOT TO SCALE

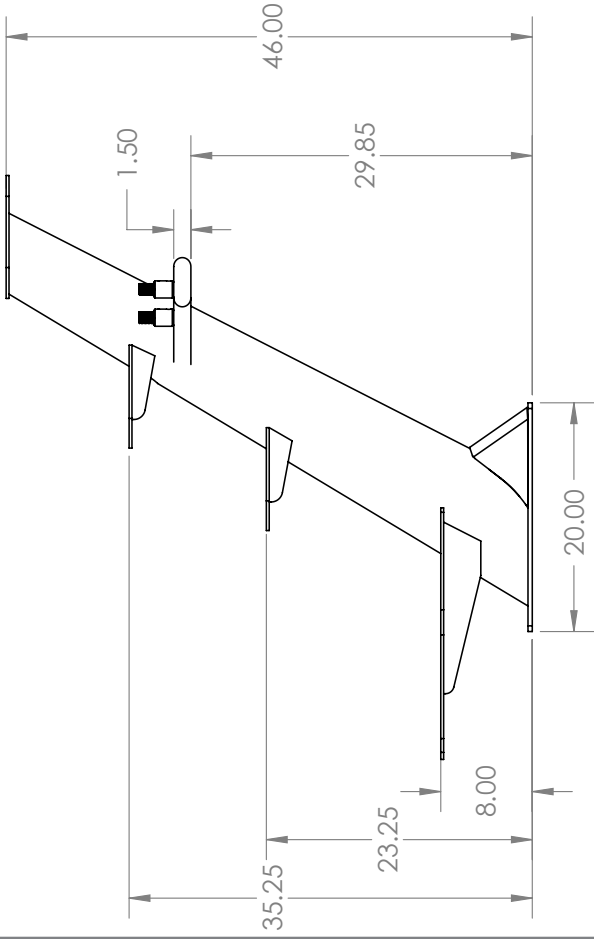
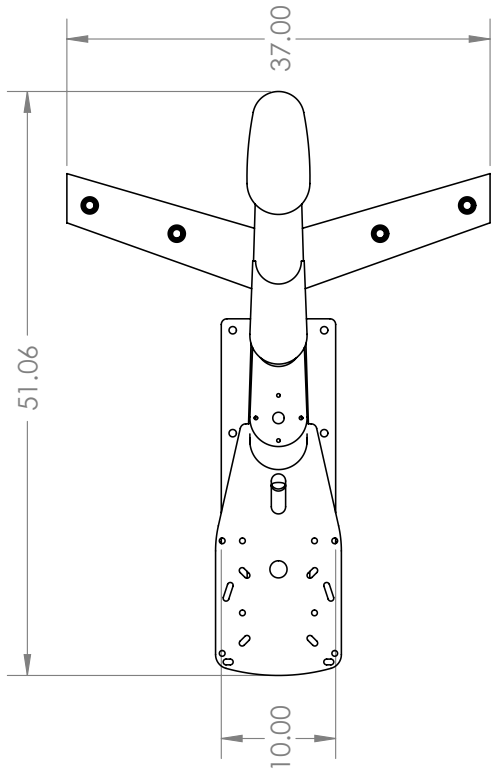

PROPRIETARY AND CONFIDENTIAL

THE INFORMATION CONTAINED IN THIS DRAWING IS THE SOLE PROPERTY OF PYI Inc. ANY REPRODUCTION IN PART OR AS A WHOLE WITHOUT THE WRITTEN PERMISSION OF PYI Inc IS PROHIBITED.

PYI Inc

TITLE: **Model 31** REV: 092110

LIST PRICE GUIDE:

Please call

SCALE: NOT TO SCALE

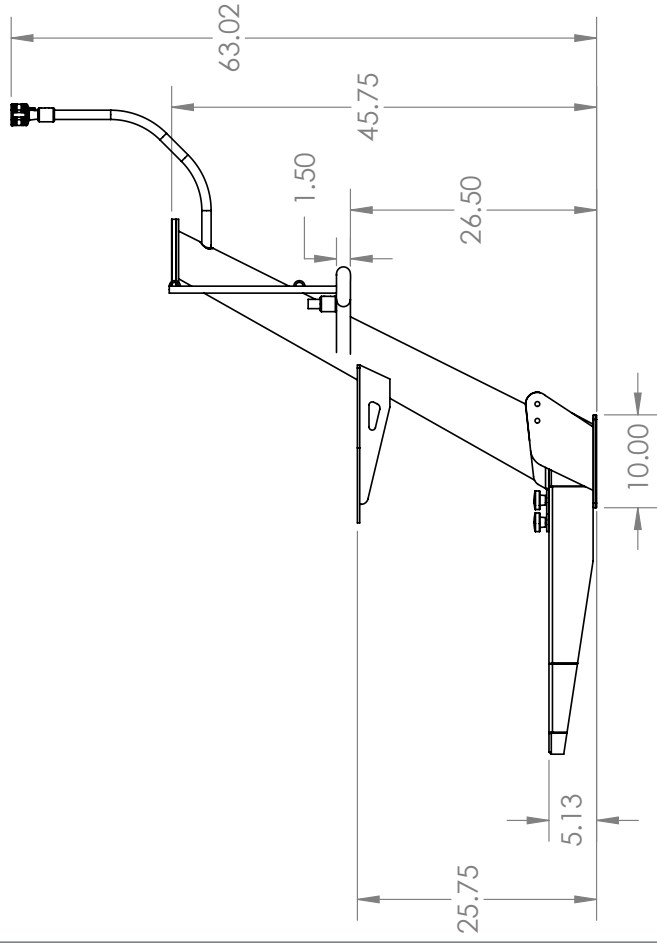
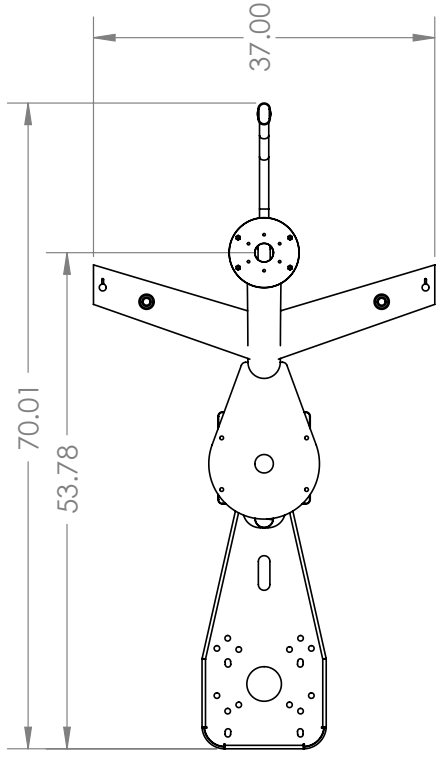

PYI Inc

TITLE: **Model 34** REV: 092110

LIST PRICE GUIDE:

Please call

SCALE: NOT TO SCALE

PROPRIETARY AND CONFIDENTIAL

THE INFORMATION CONTAINED IN THIS DRAWING IS THE SOLE PROPERTY OF PYI Inc. ANY REPRODUCTION IN PART OR AS A WHOLE WITHOUT THE WRITTEN PERMISSION OF PYI Inc IS PROHIBITED.

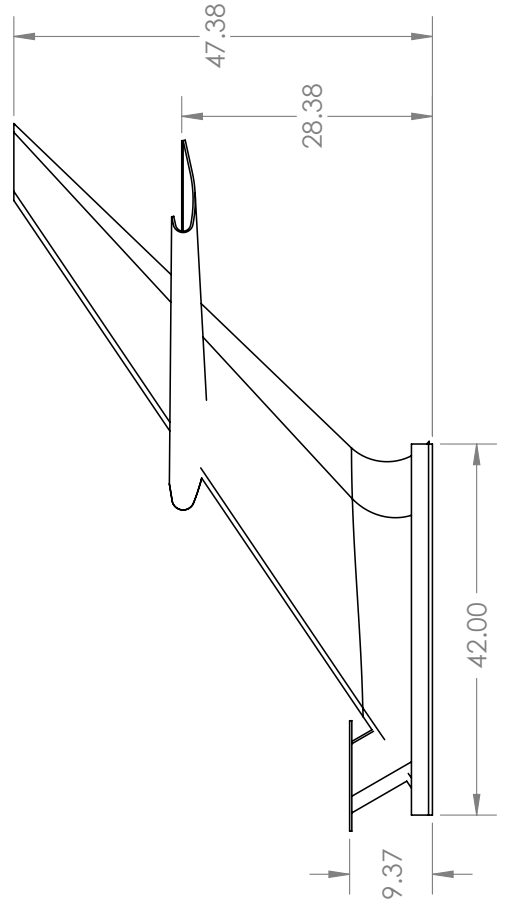
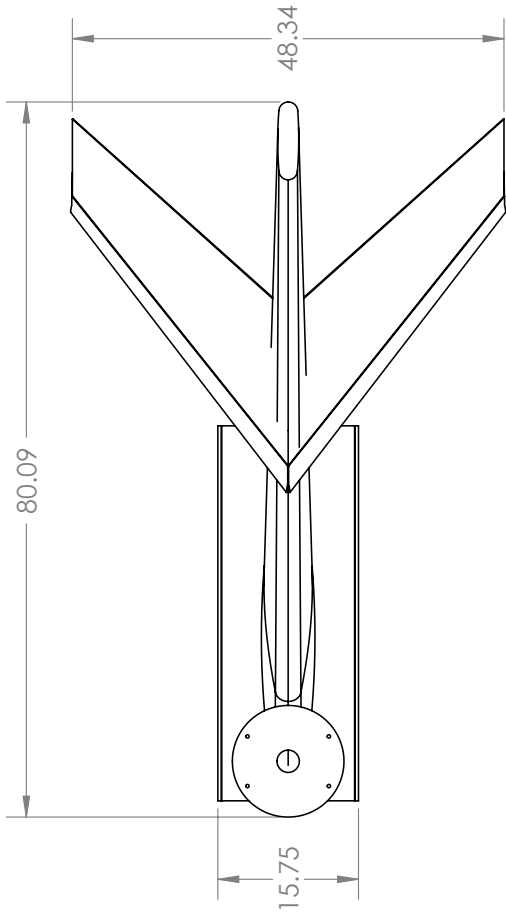

PYI Inc

TITLE: **Model 38** REV: 092110

LIST PRICE GUIDE:
Please call

SCALE: NOT TO SCALE

PROPRIETARY AND CONFIDENTIAL

THE INFORMATION CONTAINED IN THIS DRAWING IS THE SOLE PROPERTY OF PYI Inc. ANY REPRODUCTION IN PART OR AS A WHOLE WITHOUT THE WRITTEN PERMISSION OF PYI Inc IS PROHIBITED.

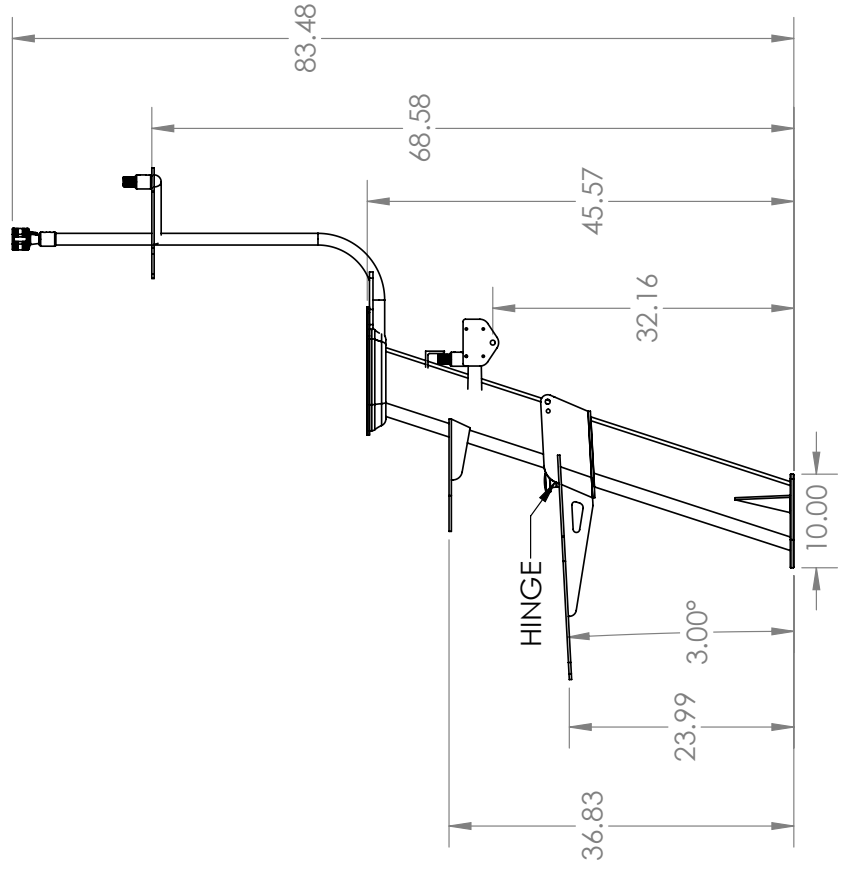
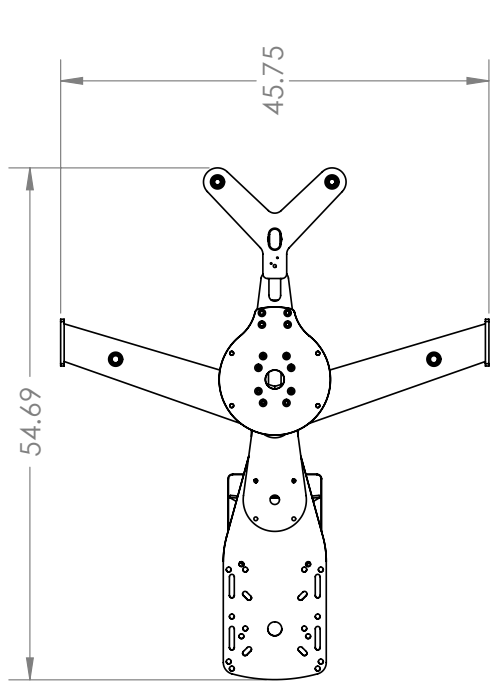

PYI Inc

TITLE: **Model 36** REV: 092110

LIST PRICE GUIDE:
Please call

SCALE: NOT TO SCALE

PROPRIETARY AND CONFIDENTIAL

THE INFORMATION CONTAINED IN THIS DRAWING IS THE SOLE PROPERTY OF PYI Inc. ANY REPRODUCTION IN PART OR AS A WHOLE WITHOUT THE WRITTEN PERMISSION OF PYI Inc IS PROHIBITED.

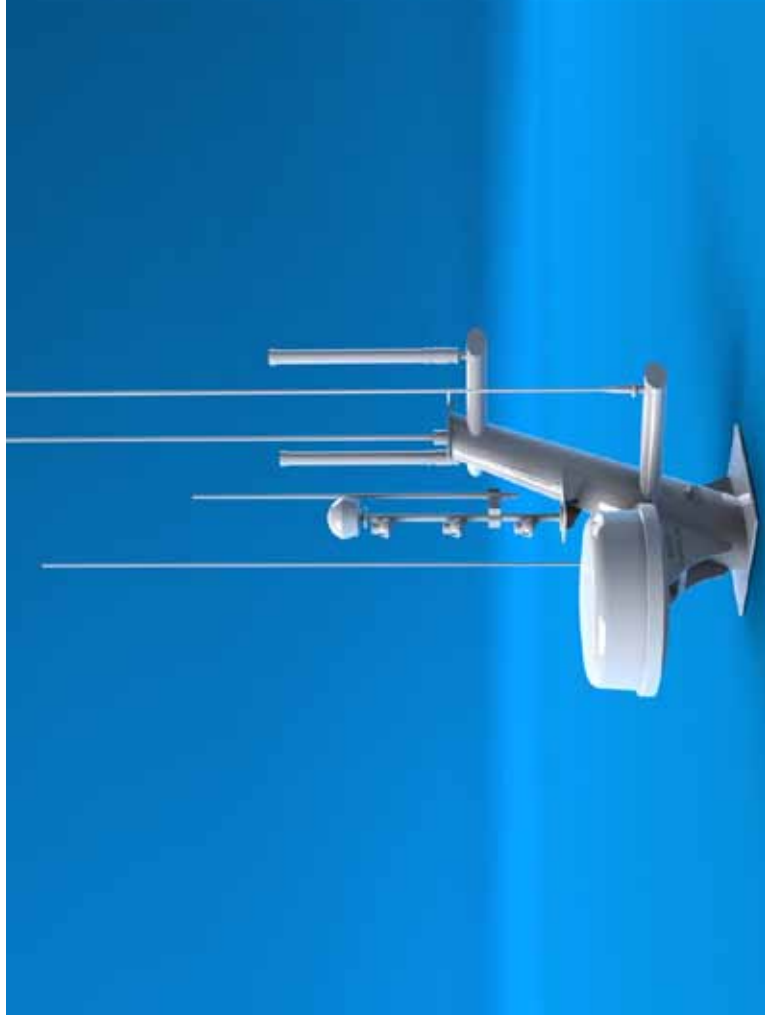
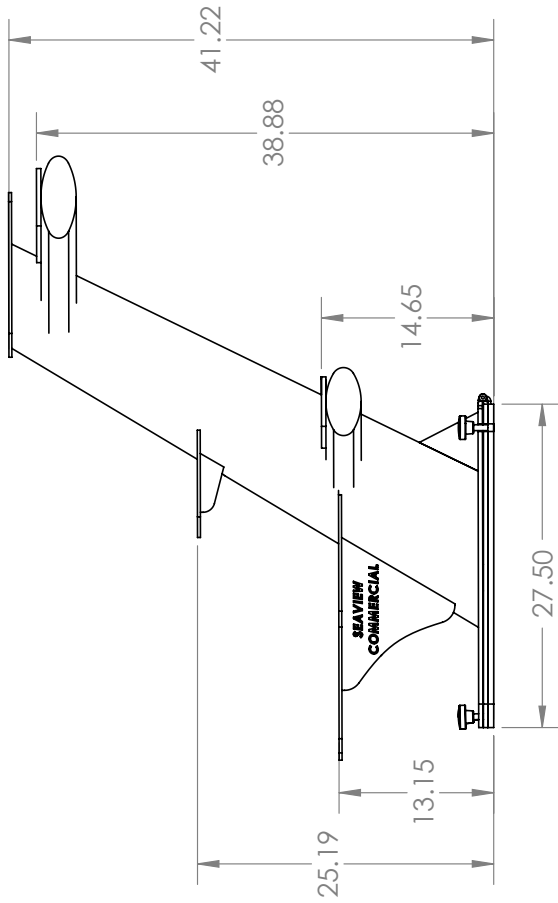
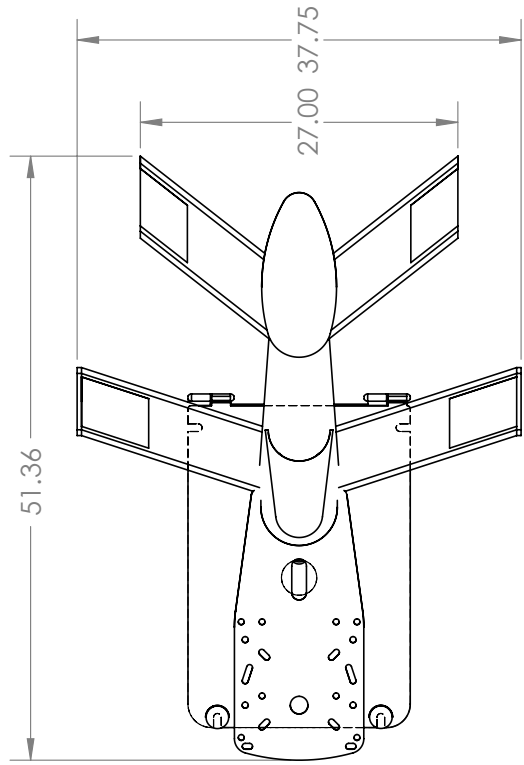

PYI Inc

TITLE: **Model 39** REV: 092110

LIST PRICE GUIDE:
Please call

SCALE: NOT TO SCALE

PROPRIETARY AND CONFIDENTIAL

THE INFORMATION CONTAINED IN THIS DRAWING IS THE SOLE PROPERTY OF PYI Inc. ANY REPRODUCTION IN PART OR AS A WHOLE WITHOUT THE WRITTEN PERMISSION OF PYI Inc IS PROHIBITED.

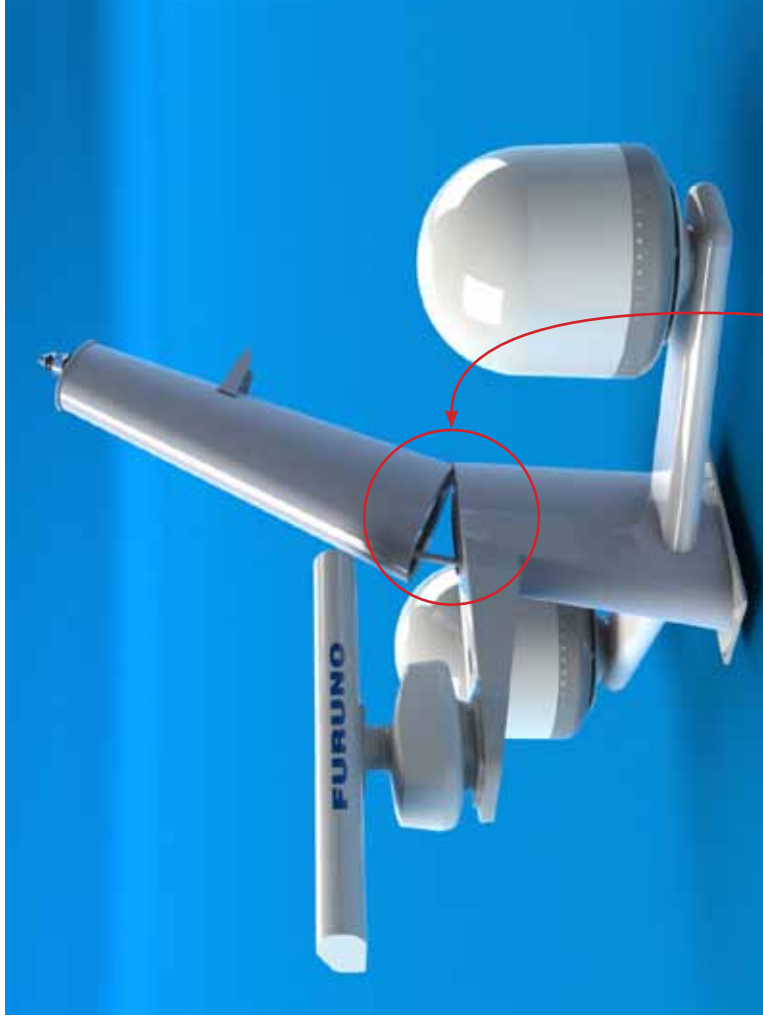
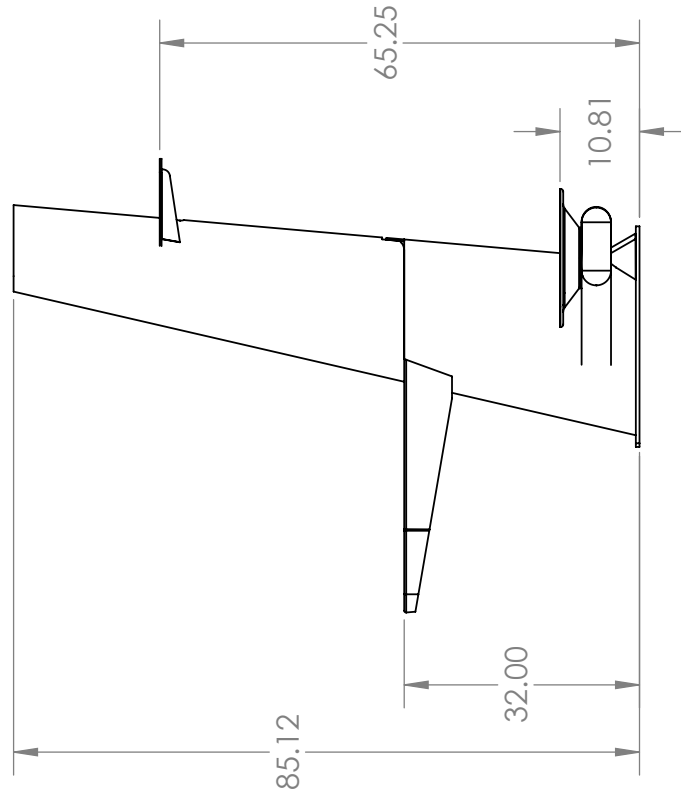
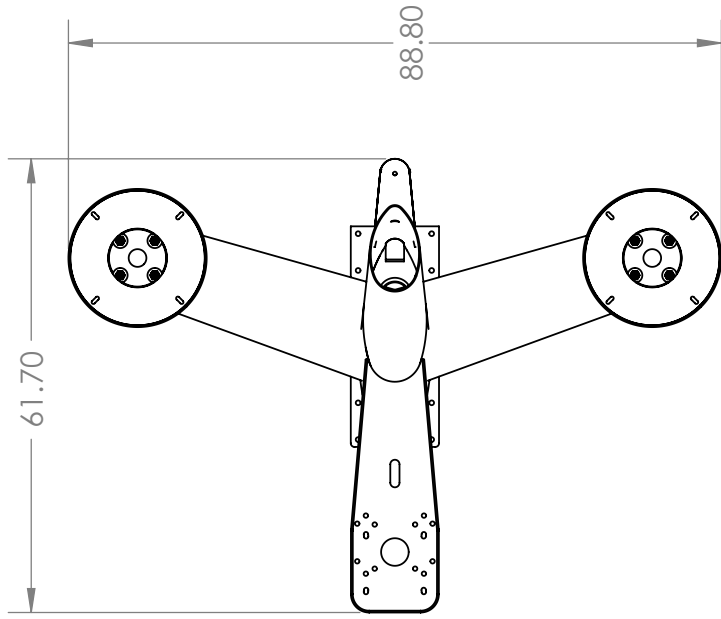

PYI Inc

TITLE: REV: 092110

Model 40

LIST PRICE GUIDE:

Please call

SCALE: NOT TO SCALE

PROPRIETARY AND CONFIDENTIAL

THE INFORMATION CONTAINED IN THIS DRAWING IS THE SOLE PROPERTY OF PYI Inc. ANY REPRODUCTION IN PART OR AS A WHOLE WITHOUT THE WRITTEN PERMISSION OF PYI Inc IS PROHIBITED.

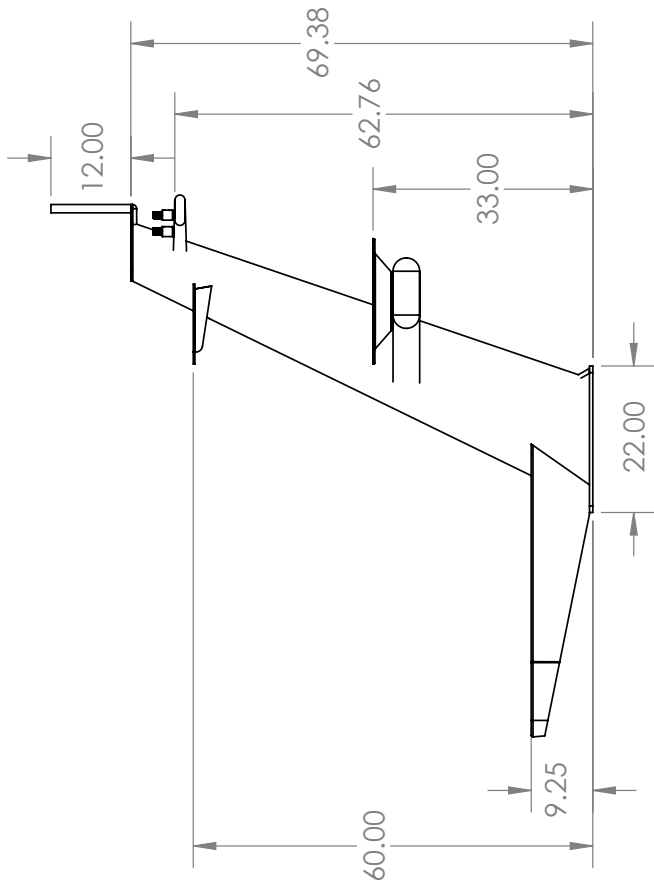
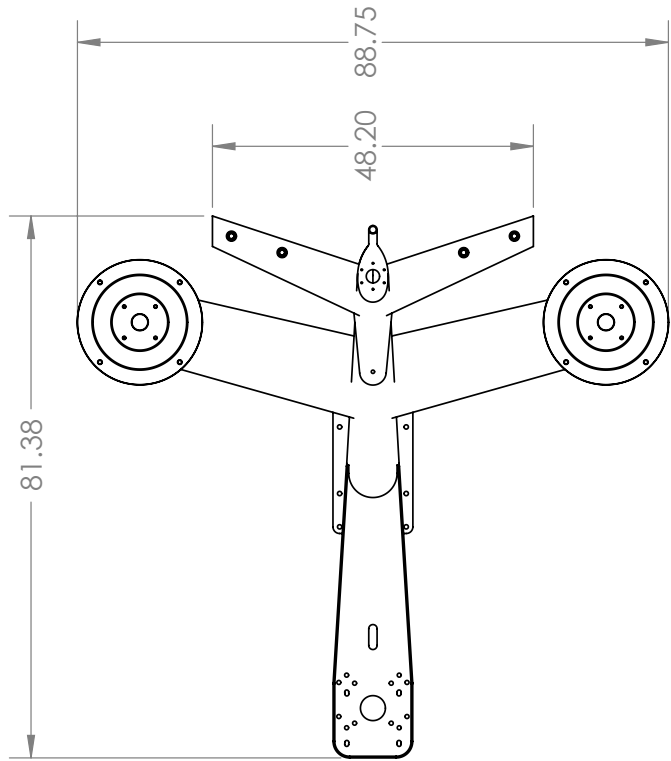

PROPRIETARY AND CONFIDENTIAL

THE INFORMATION CONTAINED IN THIS DRAWING IS THE SOLE PROPERTY OF PYI Inc. ANY REPRODUCTION IN PART OR AS A WHOLE WITHOUT THE WRITTEN PERMISSION OF PYI Inc IS PROHIBITED.

PYI Inc	
TITLE:	REV: 092110
Model 41	
LIST PRICE GUIDE: Please call	
SCALE: NOT TO SCALE	

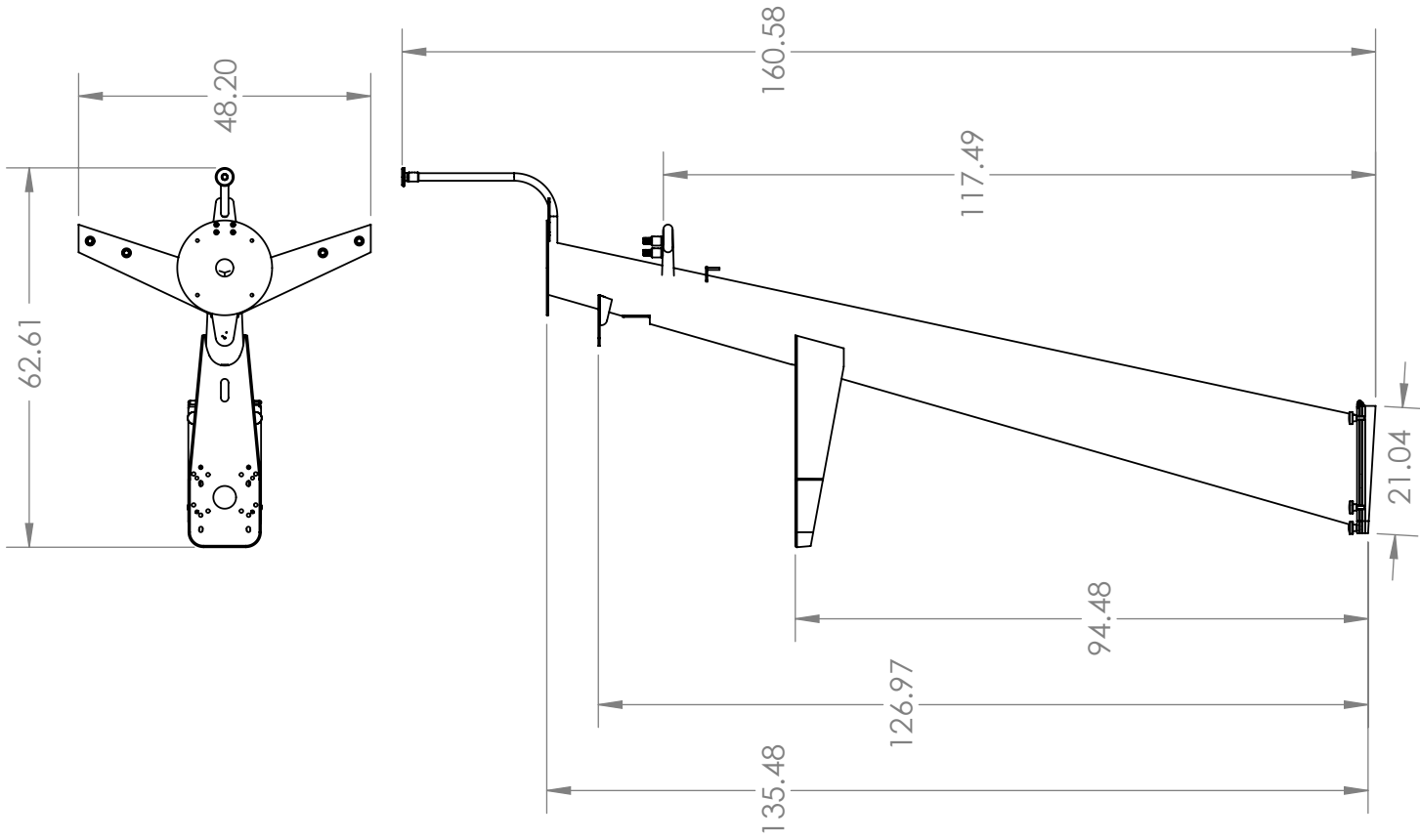

PROPRIETARY AND CONFIDENTIAL

THE INFORMATION CONTAINED IN THIS DRAWING IS THE SOLE PROPERTY OF PYI Inc. ANY REPRODUCTION IN PART OR AS A WHOLE WITHOUT THE WRITTEN PERMISSION OF PYI Inc IS PROHIBITED.

PYI Inc

TITLE: **Model 42** REV: 092110

LIST PRICE GUIDE:

Please call

SCALE: NOT TO SCALE

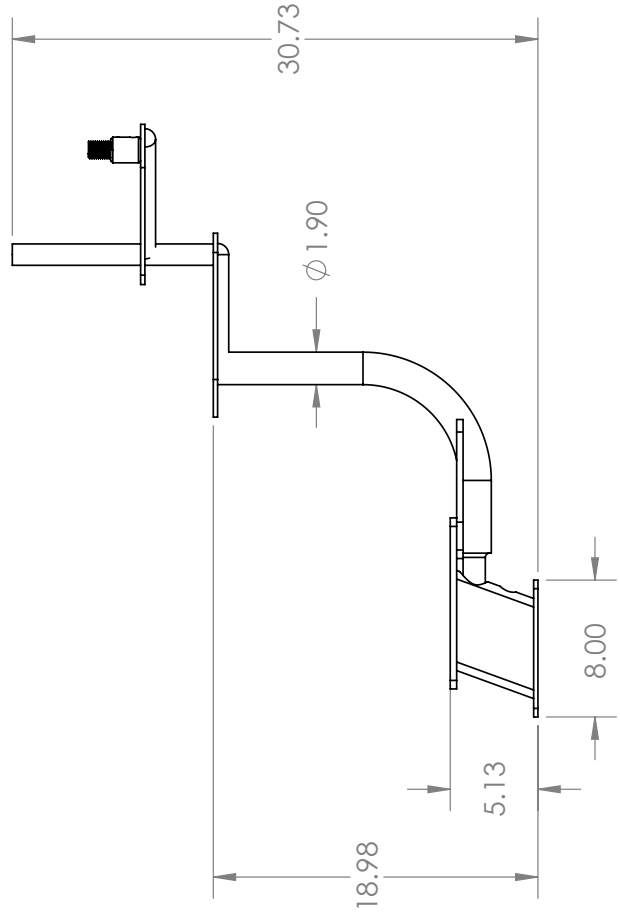
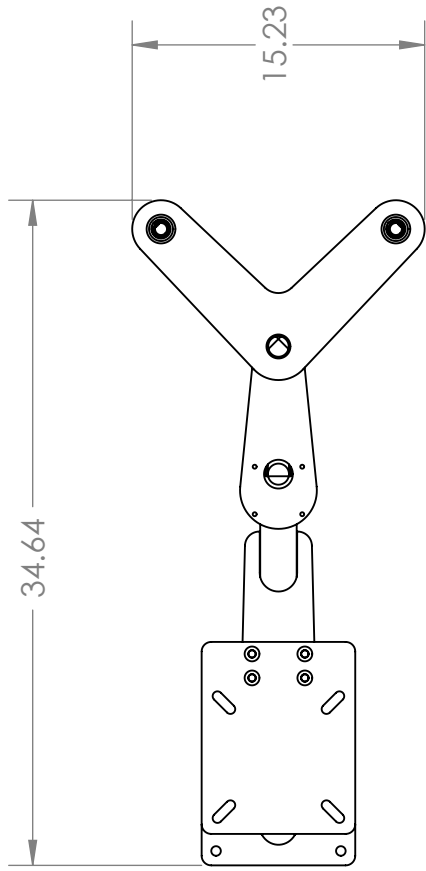

PYI Inc

TITLE: REV: 092110

Model 37

LIST PRICE GUIDE:

Please call

SCALE: NOT TO SCALE

PROPRIETARY AND CONFIDENTIAL

THE INFORMATION CONTAINED IN THIS DRAWING IS THE SOLE PROPERTY OF PYI Inc. ANY REPRODUCTION IN PART OR AS A WHOLE WITHOUT THE WRITTEN PERMISSION OF PYI Inc IS PROHIBITED.

Boats Featuring Seaview Radar/ Satcom Mounts

Meridian



Camano 31



Sea-Ray



Sabre / Back Cove Yachts



TPI (Pearson Yacht)



Oyster Yachts U.S.A.





SEAVIEW  **PROGRESS**

Europe Office

ZI du Capitou, 85 rue Louis Lepine
83600 Frejus - France

Tel: +33 4 94 5327 70
Fax: +33 4 94 5326 62
info@seavieweurope.com
www.seavieweurope.com



Headquarters

12532 Beverly Park Rd.
Lynnwood, WA 98087

Tel: (425) 523-7558
Fax: (425) 355-3661
info@pyiinc.com
www.seaviewglobal.com